

# HYPHERPRO

## STEERING DAMPER MOUNTING KIT

for

**KAWASAKI ZRX1100(N/R) '98-'00<**  
**& ZRX1200(N/R/S/DAEG) '01->**

### MK-KA12-B002 PART LIST

SD stroke 75	1	M6x70	4
Tube Clamp TYPE 1	1	M8x25 Button head	1
O-Ring	2	M8x35 Button head	1
Fork Clamp $\phi$ 43	1	Washer M8 $\phi$ 16	2
Frame Bracket Pt.1	1	Spacer TYPE 1	1
Frame Bracket Pt.2	1	Sleeve L54 (heat shrink)	4
Frame Bracket Pt.3 (rev.A)	1	-	-
M6x12	2	-	-

ALL IDEAS, DESIGNS ARRANGEMENTS AND PLANS INDICATED OR REPRESENTED BY THIS DRAWING ARE OWNED BY HYPERPRO AND WERE CREATED, EVOLVED AND DEVELOPED FOR USE ON AND IN CONNECTION WITH THE SPECIFIC PROJECT. NONE SUCH IDEAS, DESIGNS, ARRANGEMENTS OR PLANS SHALL BE USED BY OR DISCLOSED TO ANY PERSON, FIRM OR CORPORATION FOR ANY PURPOSE WHATSOEVER WITHOUT THE WRITTEN PERMISSION OF HYPERPRO.

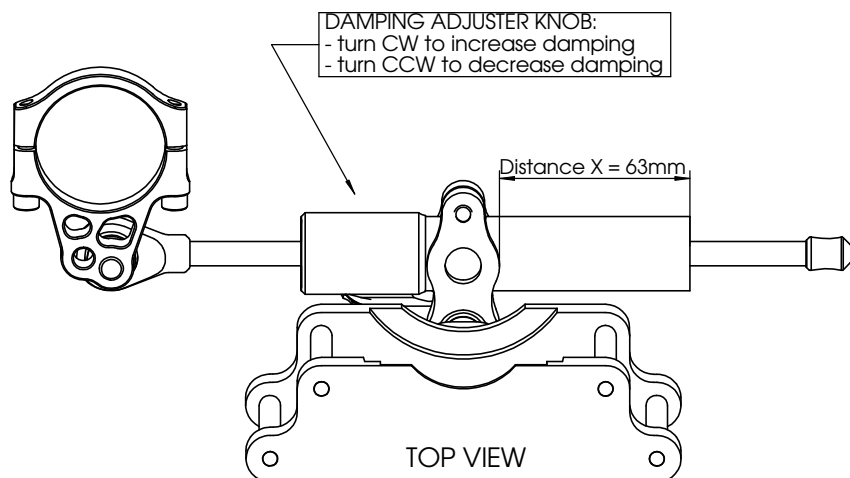

**!! DO NOT RAISE THE FORKLEGS THROUGH THE YOKES !!**

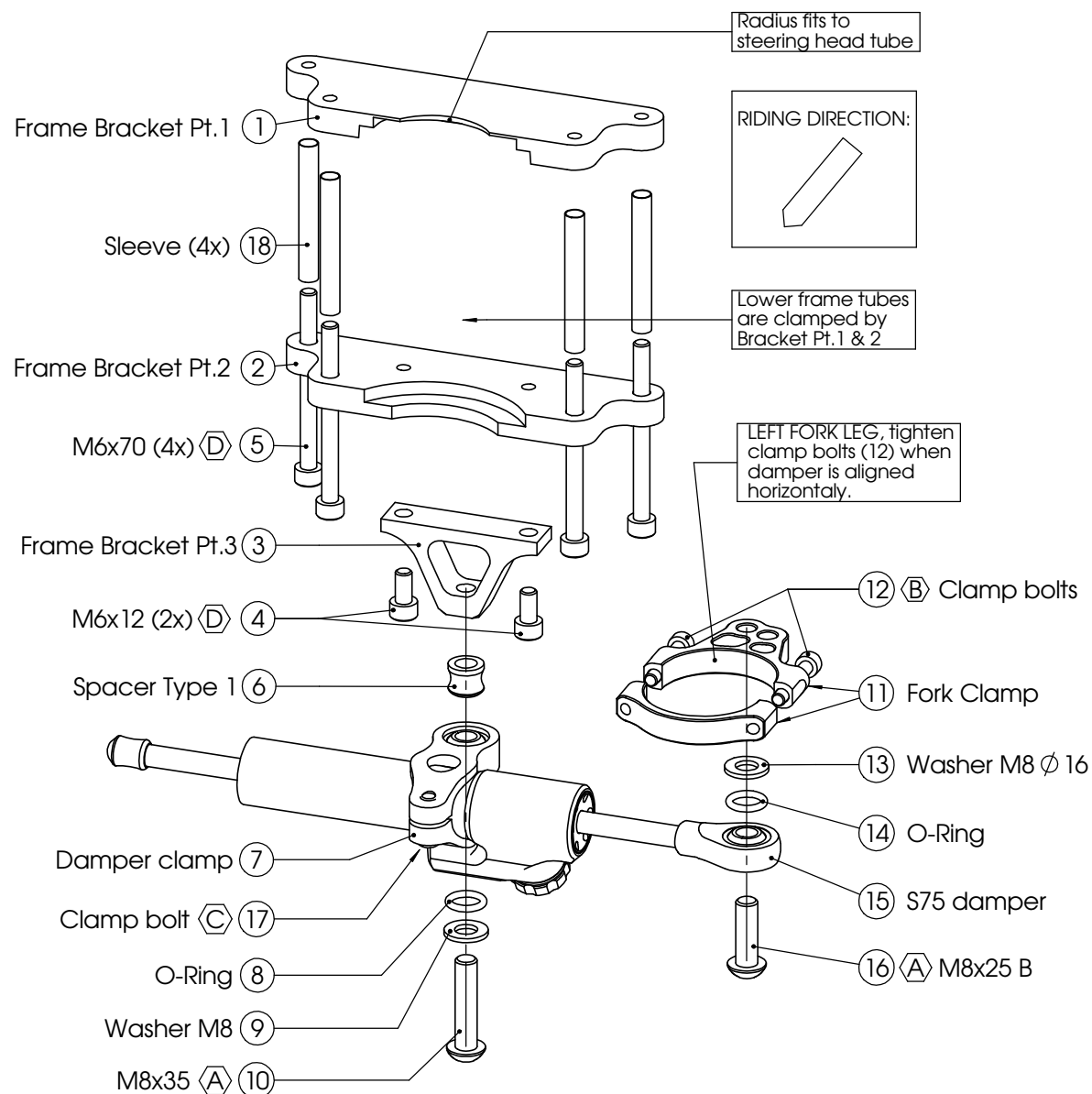

A	14-17Nm / 124-150Lbs.In / 10.3-12.5Lbs.Ft	C	6Nm / 53Lbs.In / 4.4Lbs.Ft
B	8Nm / 70Lbs.In / 5.9Lbs.Ft	D	5-9Nm / 44-80Lbs.In / 4.0-6.4Lbs.Ft

# HYPERPRO

## STEERING DAMPER MOUNTING KIT

for

**KAWASAKI ZRX1100(N/R) '98-'00<  
& ZRX1200(N/R/S/DAEG) '01->**

### **MK-KA12-B002 INSTALLATION INSTRUCTIONS**

#### ***In general:***

HYPERPRO can not be held responsible in any way for any form of physical, material, financial or other damage arising from use, assembly or overhaul of HYPERPRO products. HYPERPRO reserves the right to make changes without prior notice.

This product is only to be used for the motorcycle brand, model and year stated specifically on top of the pages of this manual.

DO NOT attempt to install this product on motorcycles from any different brand, model and/or year than stated on the pages of this manual.

DO NOT use this kit for cars, boats, jet-skies, snowmobiles, ATV's, aircraft, hovercrafts or any other vehicel and/or purpose.

HYPERPRO steering dampers are FOR RACE USE ONLY, NOT FOR HIGHWAY USE!

#### ***Before installation:***

- Please read the entire manual carefully before starting the installation!
- Check if you have all the tools required. Good tools are a must.
- Protect your bike at the most important places in and around the work area (e.g. tank, fairing, frame, etc.), with a blanket, towel or similar.

#### ***During installation:***

- Check all operations and parts carefully before, during and after performing each step.
- Clean all surfaces that are required for fitting parts together or for applying self adhesives or loctite, thoroughly with contactcleaner or another degreaser, unless otherwise stated.
- Be carefull not to damage or scratch any part of your bike.
- ALWAYS work relaxed and concentrated!! It is very easy to damage something or make a mistake.

#### ***After installation:***

- Check and make sure that there is no contact between any part of the steering damper kit and any part of the motorcycle. The kit should not hit anything. Steering movement should not be limited by the steering damper. If the steering movement is limited, adjust the position of the tube in the clamp untill steering movment is normal again. Do not forget to tighten the clamp bolt again!
- ALWAYS check the steering movement and feeling before each ride !
- FIRST RIDES: Start with the damper turned fully open (turn adjuster knob fully counter clockwise). Start adjusting in between rides with steps of MAX. 2 CLICKS (0.25 TURN) EACH TIME, untill the damper is working satisfactory for your riding style.
- NEVER USE MAXIMUM SETTING, ALWAYS OPEN AT LEAST 2 CLICKS (0.25 TURN).
- WARNING ! DAMPER HAS AN ACTIVE / SPEEDSENSITIVE DAMPING SYSTEM;
  - Steering with NORMAL MOVEMENT should be FREE !!
  - Steering with FAST MOVEMENT should be CONTROLLED BY DAMPER !!
- HYPERPRO uses a special seal to reduce friction. The seal uses an oil film to work properly. It is normal that some oil can appear on the pistonrod.
- Damper works with oil: DAMPING CAN BE HARDER AT LOWER TEMPERATURES!

#### ***Step 1: frame bracket pre-assembly***

- Frame bracket parts (2) & (3)
- 2x Bolt M6x12 (4)
- Spacer TYPE 1 (6)
- Tube Clamp TYPE 1 (7)
- 1x O-ring (8)
- 1x Washer M8  $\phi$  16 (9)
- M8x35 Button head (10)

Place frame bracket part 2 (2) carefully in a vice, bottom (with machined pockets) facing up. Place frame bracket part 3 (3) in the slot of (2) and place the M6x12 bolts (4) in the holes. Tighten the bolts with a torque of approx. 5-9Nm/44-80Lbs.In/4.0-6.4Lbs.Ft.

Now take spacer TYPE 1 (6), clamp TYPE 1 (7), O-ring (8), washer M8  $\phi$  16 (9) and bolt M8x35 (10) and place these in the correct order on frame bracket part 3 (3). Tighten the bolt with a torque of approx. 14-17Nm/124-150Lbs.In/10.3-12.5Lbs.Ft.

#### ***Step 2: installing the frame bracket***

- Frame bracket pre-assembly (2, 3, 4, 6, 7, 8, 9 &10)
- Frame bracket part 1 (1)
- 4x Bolt M6x70 (5)
- 4x Heat shrink sleeves

The bracket is to be used on the bottom frame tube, straight behind the steering head tube. Place frame bracket (1) ON TOP of the bottom frame tube, underneath all wires and cables. Place the frame bracket pre-assembly UNDERNEATH the bottom frame tube and use the bolts (5) + sleeves (18) to tighten it lightly to (1). Make sure the parts are as far to the front as possible and tighten the bolts (5) with a torque of approx. 5-9Nm/44-80Lbs.In/4.0-6.4Lbs.Ft.

#### ***Step 3: installing the fork bracket***

- Fork bracket  $\phi$  43 (11)

Disassemble the fork bracket. Place the parts around the left fork leg, about 3mm below the lower triple clamp and assemble with the two M5 bolts (12) again. Tighten lightly for positioning. Position the clamp with the M8 holes pointing backwards. The most outer hole is supposed to be on the inside of the clamp, as in the left picture on page one. The side of the clamp is supposed to be parallel to the side of the triple clamp. Tighten the bolts (15) evenly with a torque of approx. 8Nm/70Lbs.In/5.9Lbs.Ft each.

#### ***Step 4: installing the steering damper***

- Steering damper (15)
- Washer M8  $\phi$  16 (13)
- 1x O-ring (14)
- Bolt M8x25 button head (16)

Ensure that the clamp bolt of the tube clamp is pointing forward. Shove the damper (15), with the end-knob side first, through the clamp untill the balljoint (15) can be fitted to the fork bracket. Use the washer (13), O-ring (14) and M8 bolt (16) to fixate the balljoint to the bottom of the outer hole of the fork bracket and tighten with a torque of approx. 14-17Nm/124-150Lbs.In/10.3-12.5Lbs.Ft. Position the damper tube untill the distance "X" (=63mm) stated on page 1 is reached, then tighten the M6 clamp bolt (17) with a torque of approx. 6Nm/53Lbs.In/4.4Lbs.Ft.

Check if the damper is level horizontally and aligned to the bike, adjust fork clamp height if necessary. Check if the damper does not touch anything when steering from left to right. Check if the bike can make it's full steering angle from left to right.